

MODEL 2027-11

SURFACE MOUNTED COMBINATION UNIT

OPTION:

2027-10 SEMI RECESSED

2027 RECESSED

www.bradleyaustralia.com



PRODUCT FEATURES:

- Contemporary 2027-11
- Combination 2-in-1 unit:
Towel dispenser and waste receptacle
- Satin finish stainless steel

Overall Dimensions

330mm W x 1395mm H x 105mm D

PRODUCT DATA:

CONSTRUCTION:

Cabinet

Fabricated of type 304 (18-8) 22 gauge stainless steel with exposed surfaces in architectural satin finish. Welded construction with seamless corners and burr-free edges.

Door

Fabricated of type 304 (18-8) 18 gauge stainless steel, 13mm return for maximum rigidity. Concealed full-length stainless steel piano hinge, 2 tumbler locks keyed as other Bradley units.

Towel Dispenser

Fabricated of type 304 (18-8) 22 gauge stainless steel. Rolled edge on dispenser opening.

Waste Receptacle

Fabricated of satin stainless steel fully welded.

CAPACITY:

Towel Dispenser – holds Bradley Model 2001 paper hand towels.

Waste Receptacle Insert- 14 litres.

OPERATION:

Unit holds paper hand towels without the use of special adaptors.

Waste receptacle insert removable by unlocking cabinet door.

INSTALLATION:

Secure to framing with mounting screws at holes provided.

GUIDE SPECIFICATION:

Surface mounted combination towel dispenser and waste receptacle shall be fabricated of heavy gauge type 304 (18-8) stainless steel with exposed surfaces in satin finish. Cabinet door of 18 gauge stainless steel with full length concealed piano hinge and secured by 2 tumbler locks.

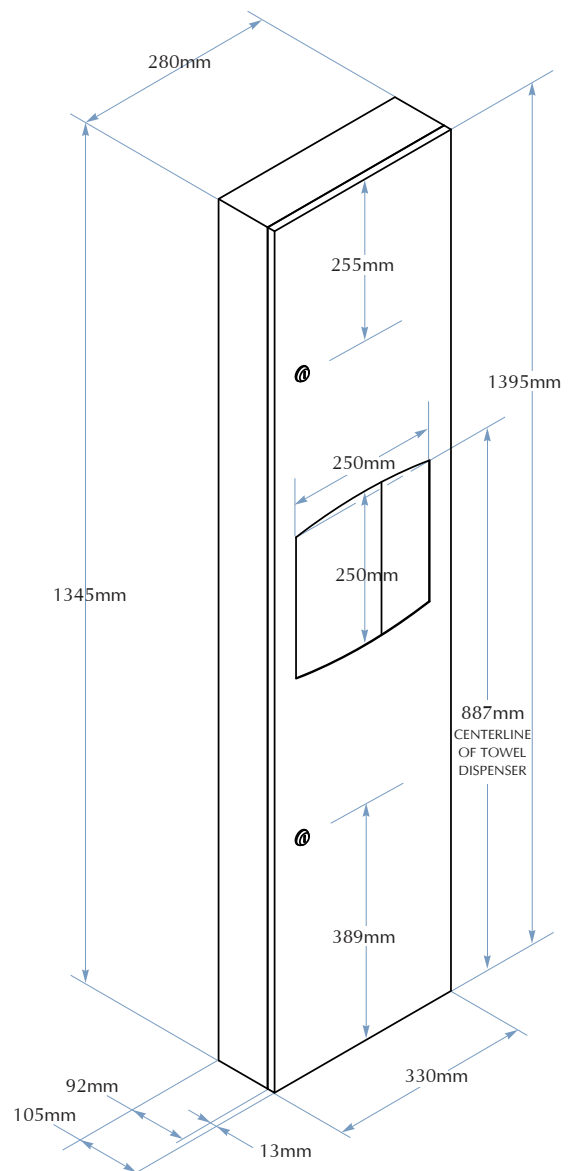

2027-11
SURFACE MOUNTED COMBINATION UNIT

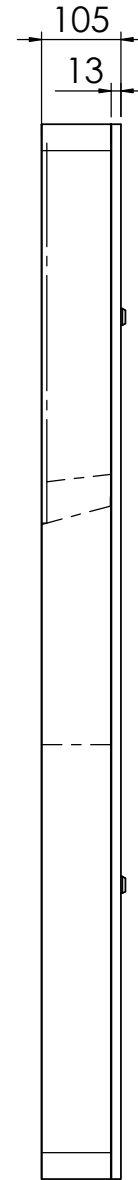
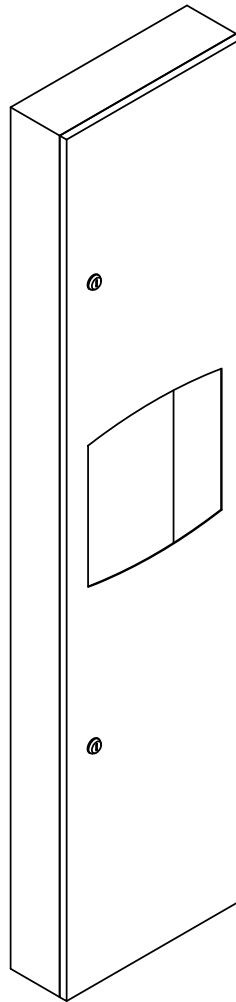
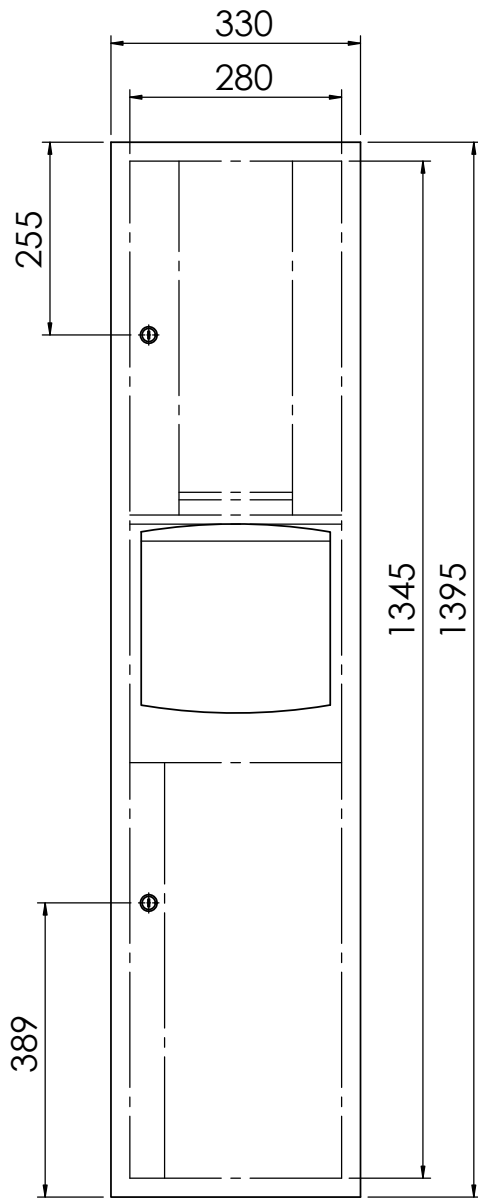

Bradley
AUSTRALIA
customised excellence

DWG NO. 2027-11

APPROVED BY:

Proudly customised design please approve SCALE:1:10