

Bradley
AUSTRALIA

customised excellence

MODEL 220-900

www.bradleyaustralia.com

AIRSTREAM 4.1 HAND DRYER 220-900



PRODUCT FEATURES:

- CPU controlled
- Wall mounted
- High speed energy saving motor

Overall Dimensions
280mm W x 300mm H x 174mm D

PRODUCT DATA:

CONSTRUCTION:

OUTER CASE: Manufactured of aluminium alloy.

MOTOR: Long-life energy saver.

ELECTRICAL SPECIFICATIONS:

ELECTRICAL SUPPLY:	240V / 50Hz / 3.75A
MOTOR:	560W / 23000rpm
ELEMENT:	340 W / 70°C / 8A/250V
AIR VELOCITY:	90m/sec
NOISE LEVEL:	78db
NETT WEIGHT:	6kg
PROTECTION CATEGORY:	IP22

RECOMMENDED INSTALLATION HEIGHT:

Men's Washroom	1200mm
Women's Washroom	1150mm
Children's Washroom (ages 11-15)	1110mm
Children's Washroom (ages 5-10)	850mm
Disabled Person's Washroom	1000mm

OPERATION:

Activation by infra-red (touch free) sensor.

INSTALLATION:

Secure to wall through back-plate with mounting screws provided.

GUIDE SPECIFICATION:

Surface mounted automatic hand dryer shall be fabricated of aluminium alloy and feature a high speed, high efficiency, energy saving motor.

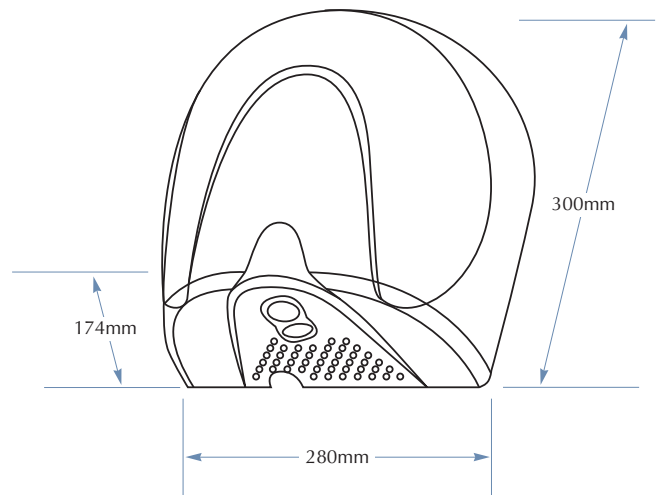

TOLL FREE 1300 364 561

The manufacturer reserves the right to make changes in design and material without formal notice and without incurring obligation.