

Bradley

AUSTRALIA

customised excellence

MODEL 220-323-MB

HAND DRYER

Options:

220-323 - Satin

220-323-MW- Matte White

www.bradleyaustralia.com



PRODUCT FEATURES:

- Matte black stainless steel
 - Wall mounted
 - 100m/s airspeed
 - Water splash proof
 - Hot and cold switch
 - Ultra slim design
 - Double hepa filter
 - 12 second dry time
 - Brushless, carbon free motor
- Overall Dimensions:
230mm W x 346mm H x 100mm D

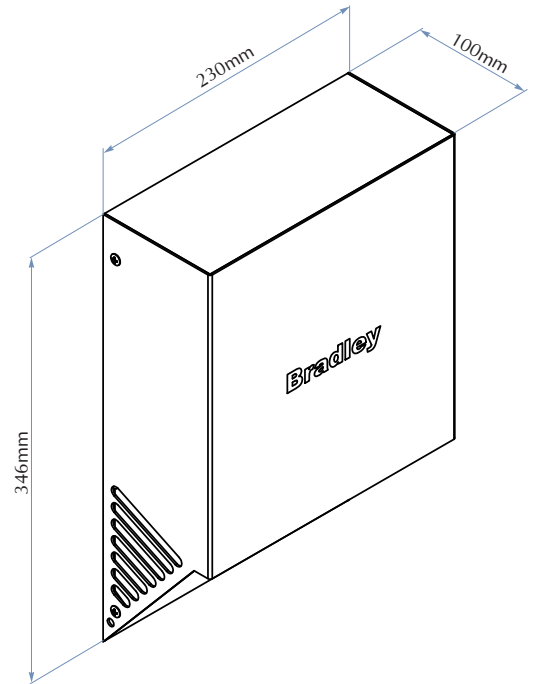

PRODUCT DATA:

CONSTRUCTION:

OUTER CASE: Manufactured of type 304 stainless steel, 2mm thick, featuring vandal resistant key.

MOTOR: Brushless high efficiency with low power consumption.

ELECTRICAL SPECIFICATIONS:

ELECTRICAL SUPPLY:	240V / 50Hz / 3.6A
RATED POWER:	700W
AIR VOLUME:	75m ³ /h
AIR VELOCITY:	100m/s
NOISE LEVEL:	>70db
NET WEIGHT:	3.3kg
PROTECTION CATEGORY:	IP22
MOTOR:	300W
VOLTAGE:	220-240v
FREQUENCY:	50/60Hz
ELECTRICAL ISOLATION:	Class I
AIR TEMPERATURE	38°C

RECOMMENDED INSTALLATION HEIGHT:

Men's Washroom	1200mm
Women's Washroom	1150mm
Children's Washroom (ages 11-15)	1110mm
Children's Washroom (ages 5-10)	850mm
Disabled Person's Washroom	1000mm

OPERATION:

Activation by infra-red (touch free) sensor. The intelligent sensor alters the temperature of the output airflow to suit the installation environment. This is an adjustable feature to be amended by a certified electrician. Automatically adjusts heating power for energy conservation.

INSTALLATION:

Requires 10 amp power supply. Secure to wall through back-plate with mounting screws provided.

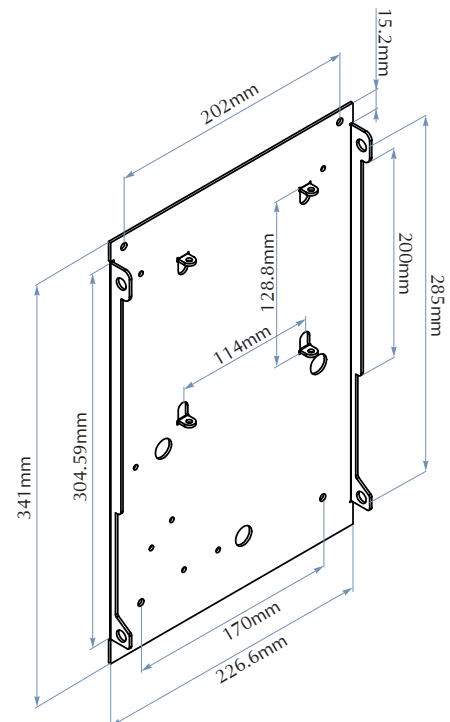

1300 364 561

The manufacturer reserves the right to make changes in design and material without formal notice and without incurring obligation.

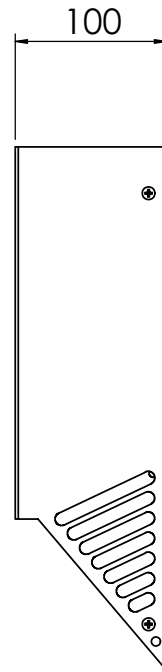
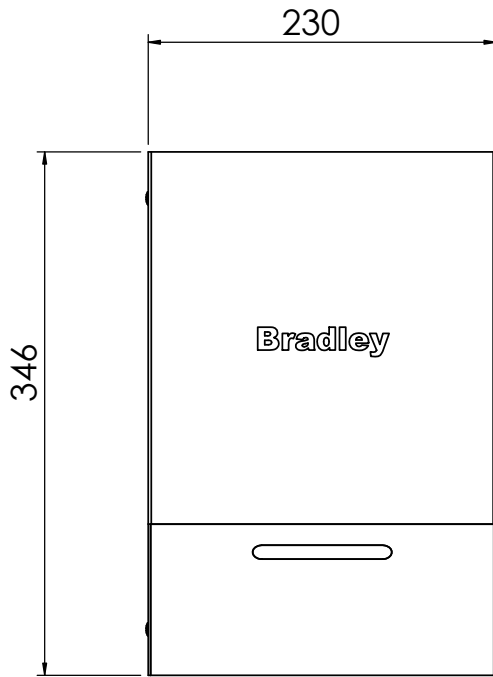
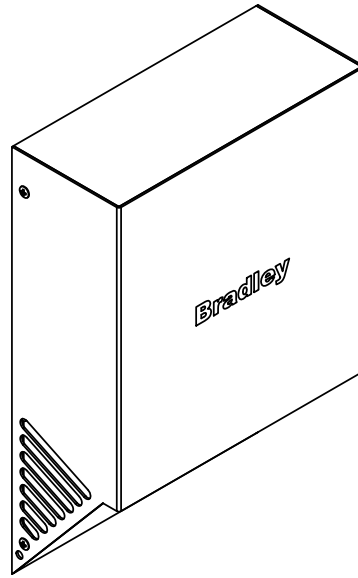

Bradley AUSTRALIA customised excellence	
DWG NO.	220-323-MB
APPROVED BY:	
Proudly customised design please approve	SCALE:1:5

220-323-MB
HAND DRYER

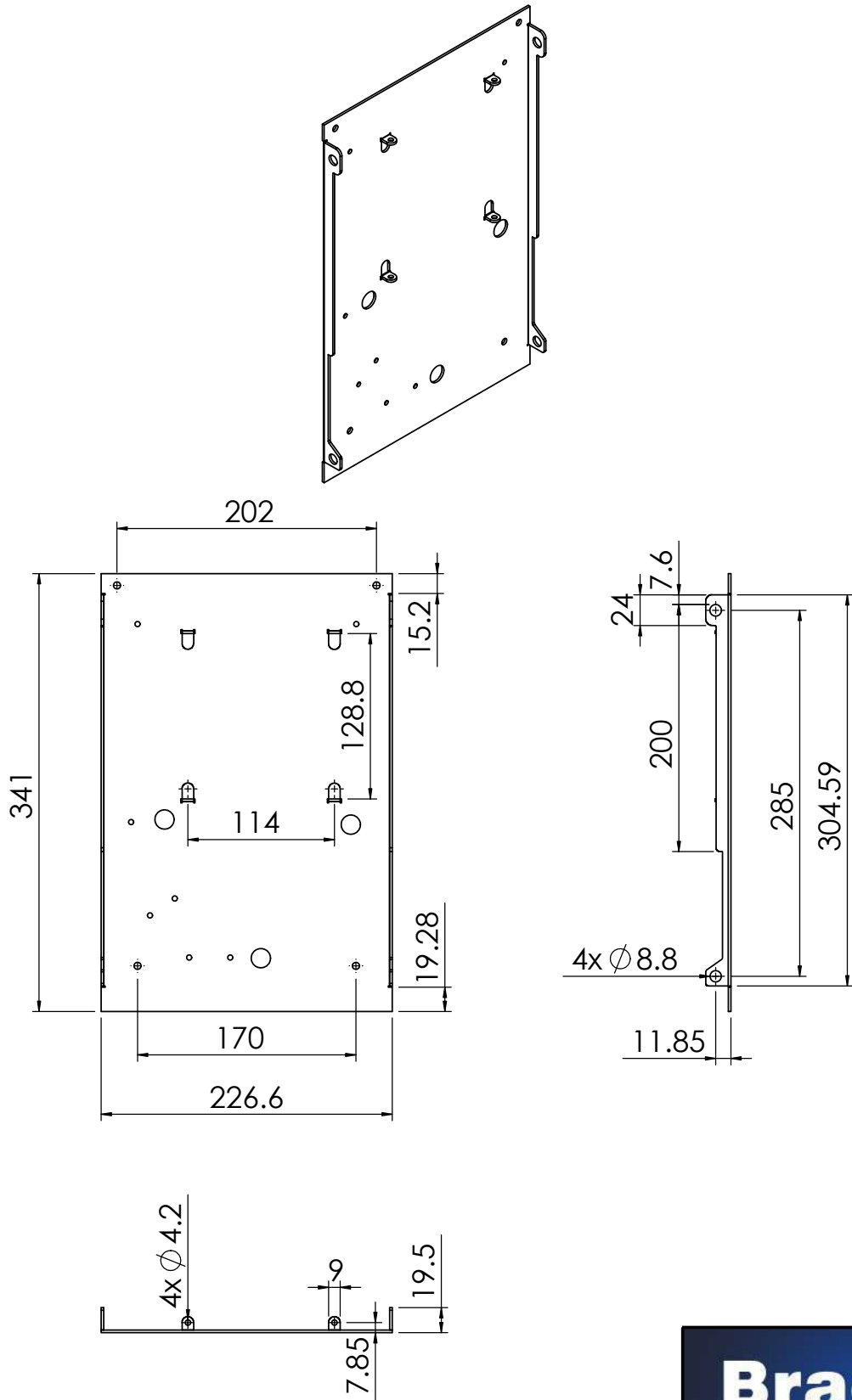

Bradley
AUSTRALIA
customised excellence

DWG NO. 220-323-MB

APPROVED BY:

Proudly customised design please approve SCALE:1:5