

Bradley

AUSTRALIA

customised excellence

MODEL 2297A

Options:

2297A-10 Semi Recessed

2297A-11 Surface Mounted

www.bradleyaustralia.com

CONTEMPORARY SERIES 2-IN-1 COMBINATION UNIT 2297A



PRODUCT FEATURES:

- Recessed combination 2-in-1 unit:
Towel dispenser and waste receptacle

- Satin finish stainless steel

Overall Dimensions
360mm W x 718mm H x 108mm D

PRODUCT DATA:

CONSTRUCTION:

CABINET: Fabricated of type 304 (18-8) 22 gauge stainless steel with exposed surfaces in architectural satin finish. Welded construction with seamless corners and burr-free edges.

DOOR: Fabricated of type 304 (18-8) 18 gauge stainless steel, 13mm return for maximum rigidity. Concealed full-length stainless steel piano hinge, tumbler lock keyed as other Bradley units.

TOWEL DISPENSER: Fabricated of type 304 (18-8) 22 gauge stainless steel. Rolled edge on dispenser opening.

WASTE RECEPTACLE INSERT: Fabricated of satin stainless steel.

CAPACITY:

Towel Dispenser – holds Bradley Model 2001 paper hand towels.

Waste Receptacle Insert - 8 litres.

OPERATION:

Unit holds paper hand towels without the use of special adaptors.

Waste receptacle insert removable by unlocking cabinet door.

INSTALLATION:

Recessed unit requires Rough Wall Opening 315mm W x 670mm H x 100mm D (semi-recessed unit only 42mm deep).

Secure to framing with mounting screws at holes provided.

GUIDE SPECIFICATION:

Recessed combination paper towel dispenser and waste receptacle shall be fabricated of heavy gauge type 304 (18-8) stainless steel with exposed surfaces in architectural satin finish. Cabinet door of 18 gauge stainless steel with full length concealed piano hinge and secured by tumbler lock.

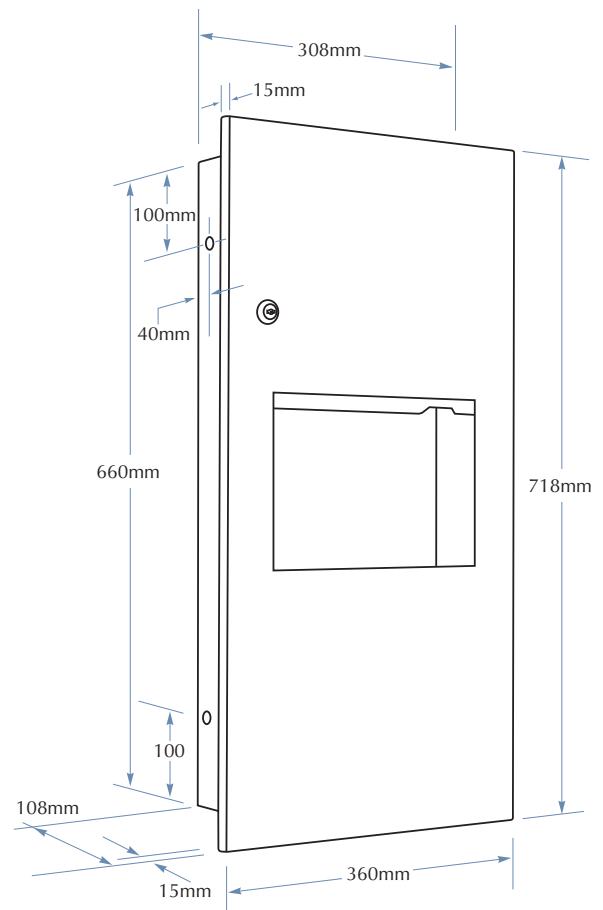

TOLL FREE 1300 364 561

The manufacturer reserves the right to make changes in design and material without formal notice and without incurring obligation.