

## RECESSED WASTE DISPOSAL UNIT

## MODEL 3257

Options:

3257-10 Semi-Recessed

3257-11 Surface Mounted



### CONTEMPORARY SERIES 3257

- Waste receptacle
- Satin finish stainless steel

Overall Dimensions  
362mm W x 718mm H x 102mm D

### CONSTRUCTION:

**CABINET:** Fabricated of type 304 (18-8), 22 gauge stainless steel with exposed surfaces in architectural satin finish. Welded construction with seamless corners and burr free edges.

**DOOR:** Fabricated of type 304 (18-8), 18 gauge stainless steel. 13mm return for maximum rigidity. Concealed full length stainless steel piano hinge and tumbler lock keyed as other Bradley units.

**PUSH FLAP DOOR:** Fabricated of type 304 (18-8), 22 gauge stainless steel with exposed surfaces in architectural satin finish. Heavy duty stainless steel piano hinge.

**WASTE RECEPTACLE INSERT:** Fabricated of stainless steel.

### CAPACITY:

10.5 litres.

### OPERATION:

Waste receptacle insert removable by unlocking cabinet door.

### INSTALLATION:

Recessed unit requires Rough Wall Opening 673mm H x 319mm W x 102mm D. Secure to framing with mounting screws (included) at holes provided. Shim at screw points as required.

### GUIDE SPECIFICATION:

Recessed waste receptacle shall be fabricated of heavy gauge type 304 (18-8) stainless steel with exposed surfaces in satin finish. Cabinet door of 18 gauge stainless steel with full length piano hinge and secured by tumbler lock. Removable 10.5 litre stainless steel insert for waste receptacle.

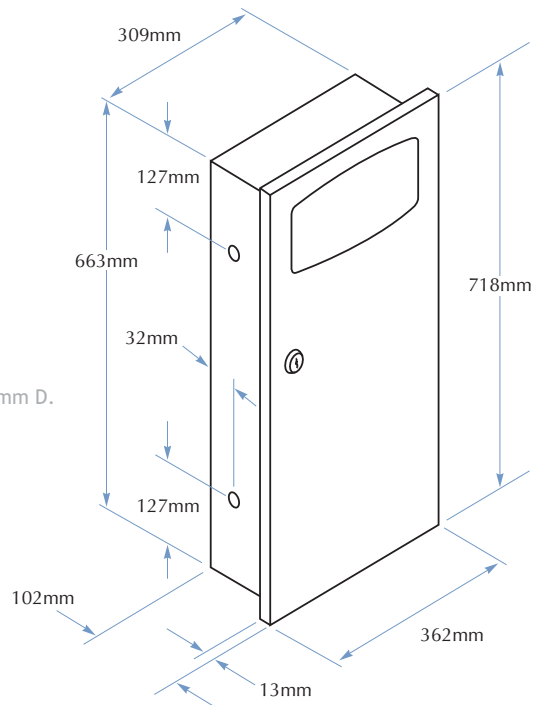

TOLL FREE 1300 364 561

The manufacturer reserves the right to make changes in design and material without formal notice and without incurring obligation.

**Bradley**  
AUSTRALIA.COM