



#### PRODUCT FEATURES:

- Satin finish stainless steel

Overall Dimensions  
203mm W x 292mm H x 105mm D

#### PRODUCT DATA:

##### CONSTRUCTION:

Fabricated of type 304 (18-8), 22 gauge stainless steel with exposed surfaces in architectural satin finish. All welded construction with rounded front corners. Bottom equipped with lock and heavy duty stainless steel piano hinge.

COVER: Fabricated of type 304 (18-8), 22 gauge stainless steel with exposed surfaces in architectural satin finish. Heavy duty stainless steel piano hinge.

##### OPERATION:

Bottom opens for removal of waxed paper liner. Additional liners available from Bradley Australia.

##### INSTALLATION:

Secure to wall or partition with mounting screws (included) at holes provided.

##### GUIDE SPECIFICATION:

Surface mounted napkin disposal shall be fabricated of type 304(18-8), 22 gauge stainless steel with exposed surfaces in satin finish. Top attached by piano hinge. Bottom hinge for easy servicing.

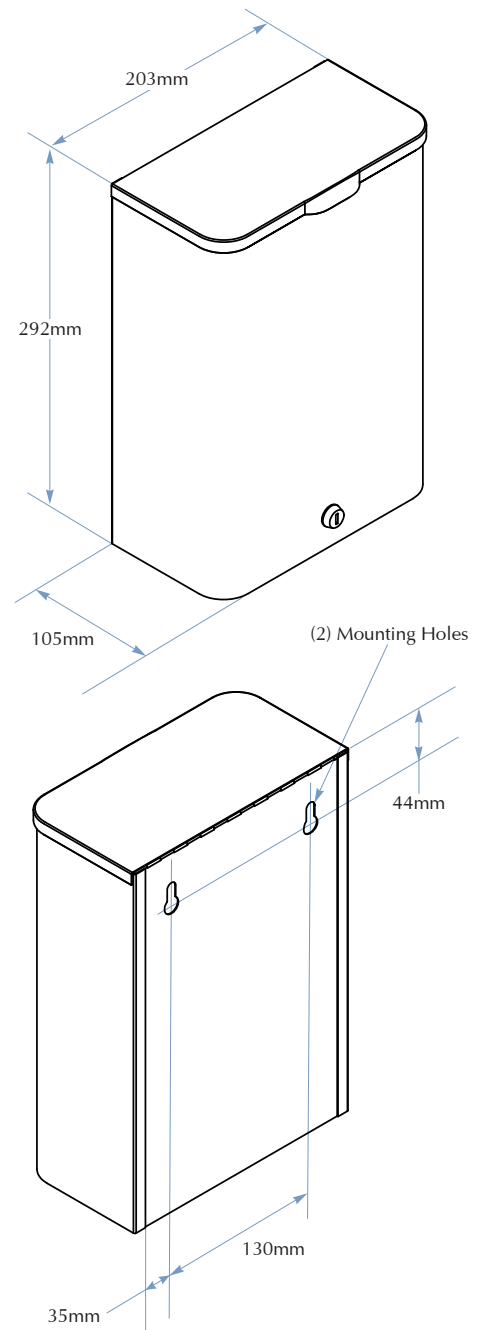

**4781-15**  
NAPKIN DISPOSAL UNIT

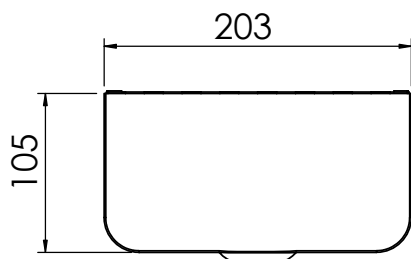
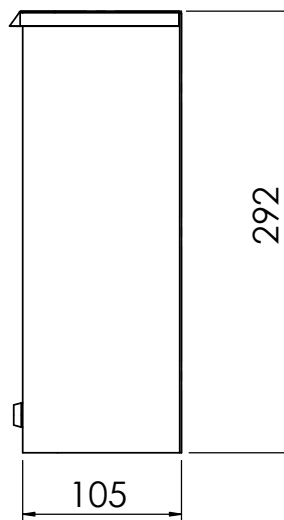
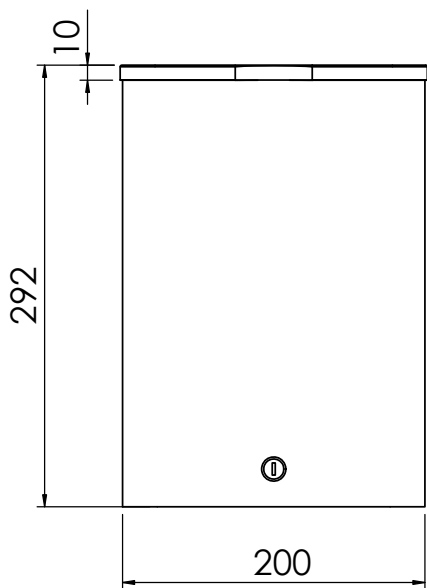
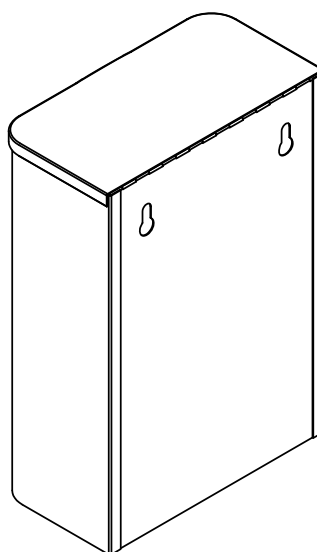
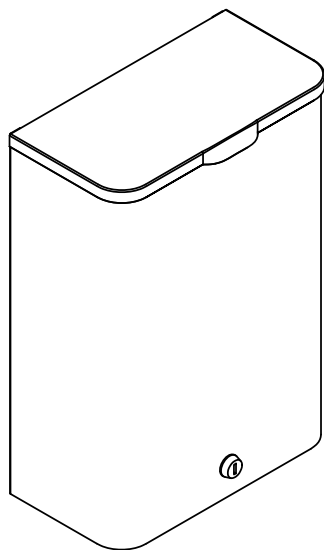

<b>Bradley</b> AUSTRALIA customised excellence	
DWG NO.	4781-15
APPROVED BY:	
Proudly customised design please approve	SCALE:1:5