



### PRODUCT FEATURES:

- High density polyethylene
- Surface mounted with concealed installation
- One handed opening and closing operation
- Easy to use and hygienic

### Overall Dimensions

Closed: 855mm W x 560mm H x 107mm D  
Open: 855mm W x 560mm H x 495mm D

### PRODUCT DATA:

#### CONSTRUCTION:

**OUTER CASE:** Fabricated of high density polyethylene. Foldable design provides space optimisation. Designed for concealed installation, achieving the integration of the aesthetic effect with the wall.

**BODY:** Antibacterial high density polyethylene. With reinforced metal plate on the back making it firm, safe and reliable.

**MOULDED LINER DISPENSER:** For storage of disposable liners.

**SAFETY BELT:** With adjustable restraint to better protect baby when in use.

**HANDLES:** To hold clothes or carry bags to keep them off the floor.

#### OPERATION:

Hinge system design, closing the table when not in use, allowing more efficient and rational use of space. Hinge bracket with metal design provides high strength and stability. The high quality gas spring design allows a one handed opening and closing operation. Designed for infants only up to 12 months weighing less than 11kg.



#### METHOD OF USAGE:

1. Unfold unit as shown on right
2. Take liner from paper holder and lay it on the table
3. Lay child in the centre of the changing table and clip together the ends of the restraint belt
4. After use, throw the liner into the trash and close the table.

#### INSTALLATION:

For complete installation instructions, see page 3 of this data sheet.

Where installed, baby change tables shall not encroach into the circulation space of any other toilet facility when in the folded position. And shall have a maximum height of 820 mm and a minimum clearance underneath of 720 mm when in the open position.

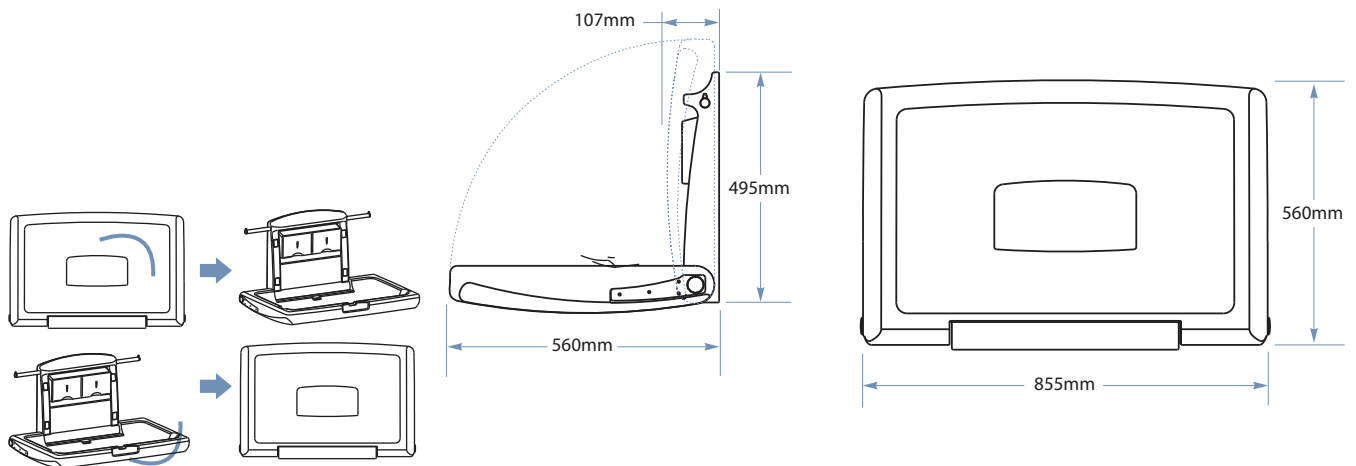

#### GUIDE SPECIFICATION:

Surface mounted unit shall be fabricated of antibacterial high density polyethylene with a reinforced metal back plate and with a sanitary disposable liner holder.

### METHOD OF INSTALLATION:

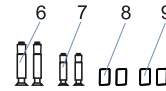
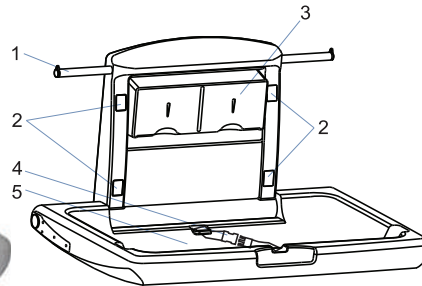

- 1. Hooks
- 2. Mounting holes
- 3. Paper holder
- 4. Restraint belt
- 5. Table
- 6. 120mm Screws
- 7. 100mm Screws
- 8. Screw Caps (Up)
- 9. Screw Caps (Down)

