

**Bradley**  
AUSTRALIA

customised excellence

[www.bradleyaustralia.com](http://www.bradleyaustralia.com)

## MODEL ICN-962 RECESSED BABY CHANGE STATION

**Option:  
ICN-962-11 Surface Mounted Unit**

### PRODUCT FEATURES:

- Satin finish stainless steel exterior
- Recessed mounted with concealed installation
- One handed opening and closing operation
- Easy to use and hygienic

#### Overall Dimensions

Closed: 940mm W x 585mm H x 104mm D - 12mm projection from wall surface

Open: 940mm W x 585mm H x 495mm D - 403mm projection from wall surface



### PRODUCT DATA:

#### CONSTRUCTION:

**OUTER CASE:** Type 304 grade satin finish stainless steel. Foldable design provides space optimisation. Designed for concealed installation, achieving the integration of the aesthetic effect with the wall.

**BODY:** Antibacterial high density polyethylene.

**MOULDED LINER DISPENSER:** For storage of disposable liners.

**SAFETY BELT:** With adjustable restraint to better protect baby when in use.

#### OPERATION:

Hinge system design, closing the table when not in use, allowing more efficient and rational use of space. Hinge bracket with metal design provides high strength and stability. The high quality gas spring design allows a one handed opening and closing operation. Designed for infants only up to 3 years and weighing less than 20kg.



## MODEL ICN-962 RECESSED BABY CHANGE STATION

Option:  
ICN-962-11 Surface Mounted Unit

[www.bradleyaustralia.com](http://www.bradleyaustralia.com)

Page 2

### METHOD OF USAGE:

1. Unfold unit as shown on right
2. Take liner from paper holder and lay it on the table
3. Lay child in the centre of the changing table and clip together the ends of the restraint belt
4. After use, throw the liner into the trash and close the table.

### INSTALLATION:

For complete installation instructions, see page 3 of this data sheet.

Where installed, baby change tables shall not encroach into the circulation space of any other toilet facility when in the folded position. And shall have a maximum height of 820 mm and a minimum clearance underneath of 720 mm when in the open position.

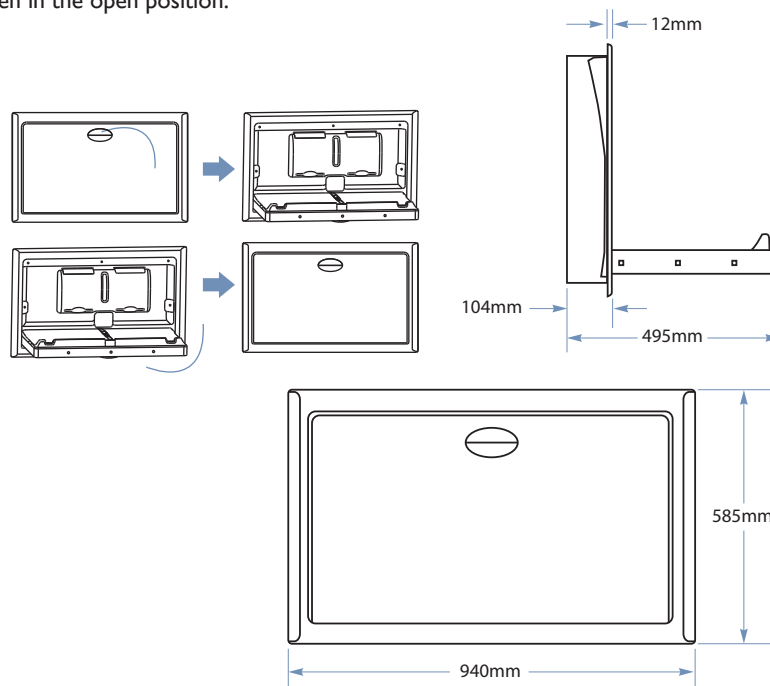

### GUIDE SPECIFICATION:

Recessed unit shall be fabricated of type 304 grade satin finish stainless steel and high density polyethylene with a sanitary disposable liner holder.

## MODEL ICN-962 RECESSED BABY CHANGE STATION

Option:  
ICN-962-11 Surface Mounted Unit

### METHOD OF INSTALLATION:

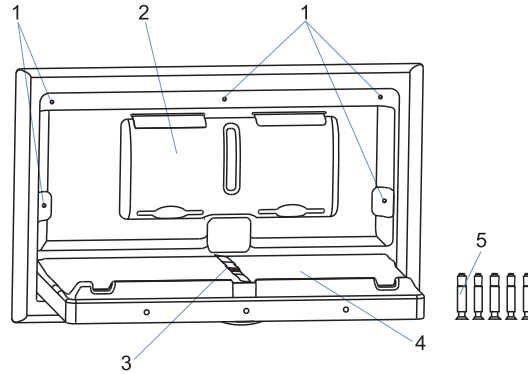

- 1. Mounting holes
- 2. Paper holder
- 3. Restraint belt
- 4. Table
- 5. Screws

